

FRP Window Retainer

Fiber Glass Reinforced Pultruded structural products are engineered not only for their high strength to weight ratio, but also to overcome other technical challenges such as corrosion and high temperatures. These pultruded structures are comprised of reinforcing fibers and resins that provide excellent structural stiffness as well as environmental, chemical, impact and fire resistance



Part No.	Description	Supplied size in Length
	1/8" Retainer	1/8" x 1" x (as Specified)

Features

- High Structural Performance
- Excellent Corrosion Resistance
- Fire Retardant
- Flame Spread of 25 or less
- High Performance at Elevated Temperatures



SPECIFICATIONS

Mechanical Property	ASTM Test	Unit	Series 1625
Tensile Strength LW	D638	psi	37,500
Tensile Strength CW	D638	psi	8,500
Tensile Modulus LW	D638	million psi	3,5
Tensile Modulus CW	D638	million psi	1.0
Compressive Strength LW	D695	psi	37,500
Compressive Strength CW	D695	psi	20,000
Compressive Modulus LW	D695	million psi	3.0
Compressive Modulus CW	D695	million psi	1.2
Flexural Strength LW	D790	psi	37,500
Flexural Strength CW	D790	psi	12,500
Flexural Modulus LW	D790	million psi	2.0
Flexural Modulus CW	D790	million psi	1.0
Modulus of Elasticity (Channels)	Full Section 2	million psi	2.8 to 3.2
(Square Tube)	Full Section 2	million psi	2.8
Shear Modulus	Full Section 2	million psi	3.2
Interlaminar Shear Strength LW	D2344	psi	0.42
Shear Strength by Punch	D732	psi	4,500
Notched Izod Impact LW	D256	ft-lb/in	6,000
Notched Izod Impact CW	D256	ft-lb/in	30
Bearing Stress LW	D953	psi	5
Bearing Stress CW	D953	psi	30,000
Poisson's Ration LW	D3039	in/in	18,000
Poisson's Ration CW	D3039	in/in	0.35
In plane Shear LW	Modified D2344	psi	0.15
In plane Shear CW	Modified D2344	psi	7,000
Clip Angle Shear Strength LW	D2344	psi	4,500
			1,450

FRP Window Retainer

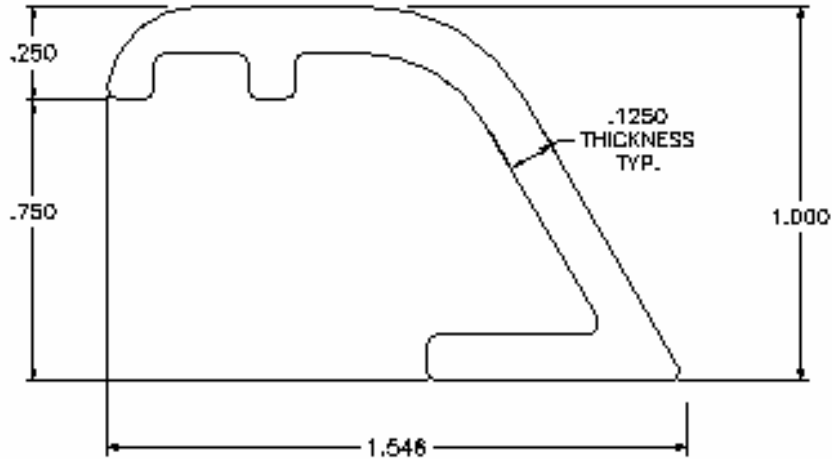

Part No.	Description	Supplied size in Length
	1/8" Retainer	1/8" x 1"x (as Specified)

SPECIFICATIONS

Mechanical Property	ASTM Test	Unit	Series 1625
Barcol Hardness	D2583		45
Water Absorption	D570	% Max	0.6
Density	D792	lbs/in 3	0.060-0.070
Specific Gravity	D792		1.66-1.93
Coefficient of Thermal Expansion LW			
	D696	millionths in/in /oF	4.4
Thermal Conductivity PF	C177	BTU-in/ft2/hr/oF	4
Electrical			
Arc Resistance LW	D495	seconds	120
Dielectric Strength LW	D149	KV/in	40
Dielectric Strength PF	D149	Volts/mil	200
Dielectric Strength PF	D150	@ 60HZ	5.2
Fire and Smoke			
Tunnel Test	E84		25 Max
Flammability Class	UL94		VO
Flammability Extinguishing	E 635		Self Extinguishing
NBS Smoke Chamber	E662		650
Flame Resistance			
Ignition/burn	FTMS 406-2023		55/30